

74-8180-250
9/12

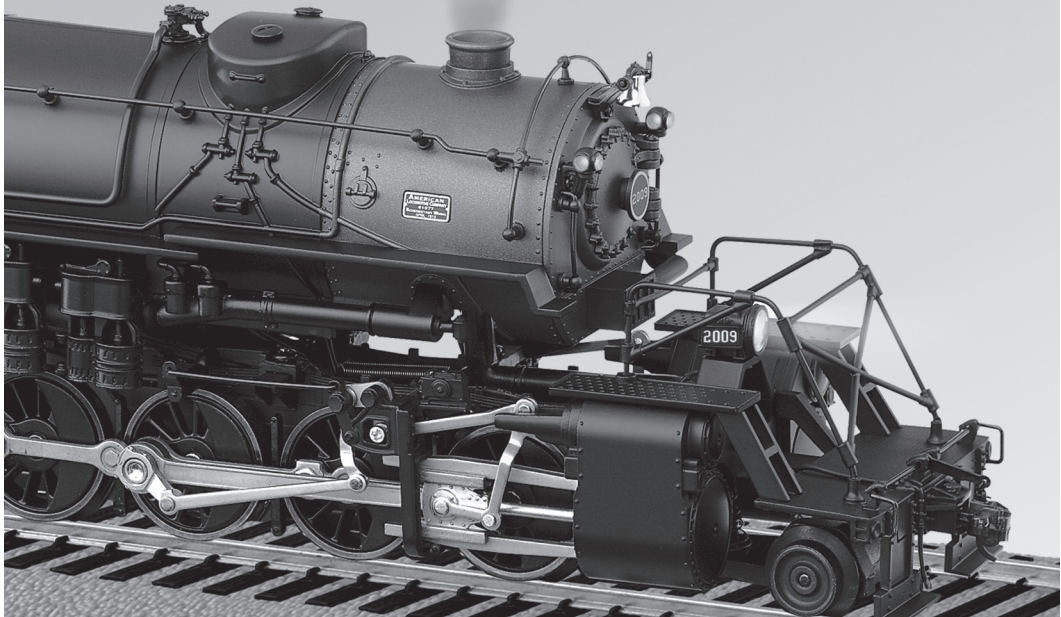

***American Flyer
2-8-8-2 Steam Locomotive
Owner's Manual***

Featuring



Congratulations!

Congratulations on your purchase of this American Flyer LEGACY steam locomotive! On the outside, this locomotive features numerous details and expert decoration in your favorite livery. Inside the body, this locomotive is equipped with some of the most advanced sounds and controls in model railroading. This powerful locomotive is ready for duty on your layout.

Features of this locomotive

- LEGACY Control System equipped — able to run in LEGACY Control mode, Trainmaster Command Control mode or in Conventional mode with most American Flyer and Lionel transformers
- AF Speed Control
- LEGACY RailSounds sound system featuring:
 - CrewTalk dialog and TowerCom announcements, each with different scenarios depending on whether the locomotive is in motion or stopped
 - Six official preset speeds with CrewTalk dialog
 - DynaChuff synchronized chuffing that shifts through 15 levels of intensity as the locomotive gains speed
 - LEGACY ‘Real-Time Quilling Whistle’ control with instant response for realistic signature ‘quilling’ and correctly timed warning signals
 - Single hit or continuous mechanical bell sounds
 - Independently adjustable volume control
- All-new Scale tooling
- Wireless Tether connection between locomotive and tender
- Two powerful motors with momentum flywheel
- ElectroCoupler on rear of tender
- Operating headlight and classification lights
- Directional lighting, including backup light on rear of tender
- Illuminated number boards
- Interior illumination in cab
- Die-cast metal locomotive body, frame, and trucks
- Traction tires
- Opening hatches
- Synchronized fan-driven smoke unit
- Separately applied metal details
- Separately applied builder’s plates
- Cab window glass
- Variable ashpan glow
- Flickering firebox
- Engineer and fireman figures
- Die-cast metal tender body and trucks
- “Doghouse”-style tender on N&W and PRR
- Prototypical road-specific details
- Length: Approx. 21 1/2”
- Minimum Curve: 36” diameter

Table of contents

Running your locomotive

LEGACY Control operations	4
TrainMaster Command Control (TMCC/Command) operations	5
Conventional transformer operations	6

Locomotive basics

Adding smoke fluid to your locomotive's smoke generator	7
Locomotive switch locations	8
Assigning your locomotive a new ID# (LEGACY and TMCC)	9
Lash-ups (for LEGACY operations only)	10

LEGACY Control System operations

The LEGACY CAB-2 Remote Controller	11
The Velocity Throttle	12
The Multi-Controller	12
The Train Brake Slider	12
The Warning Sound Controller	13
The Speed Bar	13
EFX Trim and EFX Bar Graph	14
Leaving the Preset Speed Screen	14

LEGACY RailSounds sound system operations

LEGACY RailSounds sound system	15
Installing the battery	16
CrewTalk dialog and TowerCom announcements in the LEGACY environment	17
LEGACY RailSounds sound system dialog on a round trip	18

TrainMaster Command Control operations

CAB-1 Remote Controller commands	19
CAB-1 Remote Controller numeric keypad commands	20-21
Controlling the smoke level and cab lights	21

Conventional transformer operations

Using the LEGACY RailSounds sound system in the conventional environment	22
Activating CrewTalk dialog and TowerCom announcements	22
Locking your locomotive into a single direction	23

Maintaining and servicing your locomotive

Reprogramming your locomotive to restore features (LEGACY)	24
Reprogramming your locomotive to restore features (TMCC)	24
Lubricating your locomotive	25
Servicing your locomotive's LEDs	26
Replacing the traction tires	26
Notes	27
Lionel Warranty	28

The following Lionel marks are used throughout this Owner's Manual and are protected under law. All rights reserved.

Lionel®, LEGACY™, FasTrack®, TrainMaster®, Odyssey®, RailSounds®, CrewTalk™, TowerCom™, DynaChuff™, StationSounds™, Pullmor®, ElectroCoupler™, Magne-Traction®, CAB-1® Remote Controller, American Flyer®, Lionel ZW®, ZW®, MagniVision®, TMCC®, Lionelville®, Wireless Tether™, Powerhouse™, LionMaster®, Conventional Classics™, Postwar Celebration Series™, TruRail™, PH-1 Powerhouse®, Powermaster®, Powerstation-Powerhouse®, Accessory Motor Controller™, AMC™, Accessory Switch Controller™, ASC™, Action Recorder Controller™, ARC™, Track Power Controller 300™, TPC 300™, Track Power Controller 400™, TPC 400™, Block Power Controller™, BPC™, Operating Track Controller™, OTC™, FatBoy™, Lionel Lines®, Joshua Lionel Cowen Series™, Lockon®, TrainSounds™, MultiHorn™, MultiWhistle™, Choo-Choo™

Running your locomotive

Note! Power your locomotive with an alternating-current (50-60Hz AC) transformer only. Powering your locomotive with a direct-current (DC) transformer, or in excess of 19 volts AC, may result in damage to sensitive electronic components.

Note! Your locomotive requires curves that have a 36" or larger diameter, measured from center point between rails to center point between rails.

LEGACY Control operations

For the finest operating experience, your locomotive is fully compatible with the LEGACY Control System. To operate in LEGACY mode, you need a LEGACY Command Base and LEGACY CAB-2 Remote Controller (6-14295).

Your commands are sent by the CAB-2 Remote Controller to the Command Base, which sends a digital code through the rails to your locomotive. Your locomotive will not respond until it recognizes its unique ID#, so you can operate multiple Command-equipped locomotives on the same track at the same time.

1. Turn off track power, and then plug in the LEGACY Base and connect it to the track.
2. Place your locomotive on the track.
3. Increase track power voltage to full power (no more than 19 volts AC). If a circuit breaker trips when you turn on the Lionel power supply, check the wheels of your locomotive to make sure they are all securely on the track. Check to make sure the track is free of all metals that may cause a short circuit.
4. As illustrated in Figure 1, press ENG and 1 (or your selected ENG ID#) to address the locomotive with your LEGACY CAB-2 Remote Controller.

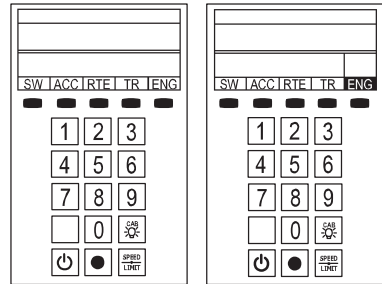

Figure 1. LEGACY engine selection

5. Press the Start Up button on your LEGACY CAB-2 Remote, shown in Figure 2. Then, throttle up and move 'em out! Your engine sound will start up, and the locomotive-specific touch screen buttons will populate the remote. For more information on operating your locomotive with the LEGACY system, please refer to the LEGACY section of this manual. Additional information is also found in the LEGACY System Manual, available online at www.lionel.com.

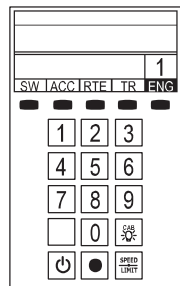

Figure 2. LEGACY start-up

Running your locomotive

Note! Power your locomotive with an alternating-current (50-60Hz AC) transformer only. Powering your locomotive with a direct-current (DC) transformer, or in excess of 19 volts AC, may result in damage to sensitive electronic components.

Note! Your locomotive requires curves that have a 36" or larger diameter, measured from center point between rails to center point between rails.

TrainMaster Command Control (TMCC) operations

For operation in the TrainMaster Command Control environment, you need a TrainMaster Command Base (6-12911) and a CAB-1 Remote Controller (6-12868). Refer to your TMCC System Manual for complete information. **To access all the locomotive's features, you must operate in the LEGACY environment, as discussed on the previous page.**

Your commands are sent by the CAB-1 Remote Controller to the Command Base, which translates the command into digital code. That code is sent through the outside rails to your locomotive, which will not respond until it recognizes its unique ID#. TrainMaster Command Control gives you the power to operate multiple Command-equipped locomotives on the same track at the same time.

- 1. Turn off track power, and then plug in the Command Base and connect it to the track.**
- 2. Place your locomotive on the track.**
- 3. Increase track voltage to full power (no more than 19 volts AC).** If a circuit breaker trips when you turn on the Lionel power supply, check the wheels of your locomotive to make sure they are all securely on the track. Check to make sure the track is free of all metals that may cause a short circuit.
- 4. Press ENG and 1 (or the ENG ID# you set) to address your locomotive with your CAB-1 Remote Controller.**
- 5. Throttle up and move 'em out.**

For more information, please refer to the TrainMaster Command Control operations section of this manual or the TMCC System Manual, available online at www.lionel.com.

Running your locomotive

Conventional transformer operations

Note! For Conventional operation, a Command Base must not be powered up anywhere in the area, even if it is not connected to the track. If a base is detected, your locomotive will default to Command mode.

Note! Power your locomotive with an alternating-current (50-60Hz AC) transformer only. Powering your locomotive with a direct-current (DC) transformer, or in excess of 19 volts AC, may result in damage to sensitive electronic components.

Note! Your locomotive requires curves that have a 36" or larger diameter, measured from center point between rails to center point between rails.

Caution! Set the smoke unit switch to the Off position if you will be making multiple direction changes to prevent overheating the smoke unit. See Figure 4 on page 8 for the location of this switch.

- 1. With track power off, place your locomotive on the track.**
- 2. Power up the track (8-18 volts AC). Starting voltage will vary based on the locomotive's load.** If a circuit breaker trips when you turn on the Lionel power supply, check the wheels of your locomotive to make sure they are all securely on the track. Check to make sure the track is free of all metals that may cause a short circuit.
- 3. Move 'em out!** When the locomotive's headlight illuminates and the LEGACY RailSounds sound system starts, press the DIRECTION button on your transformer to sequence your locomotive through the repeating pattern of operations: neutral, forward, neutral, reverse, neutral, and so on. You may also briefly turn off track power to advance the locomotive to the next operating state. Adjust the throttle until your locomotive moves at your desired speed.

Note! When placing your locomotive on your layout for the first time and after power interruptions lasting longer than five seconds, it will start out in neutral.

Use the **HORN** and **BELL** buttons on your transformer to activate those features. Adjust the volume using the volume control knob. Refer to Figure 5 on page 16 for the location of this control. For more information, please refer to the Conventional transformer operations section of this manual.

Note! If the **HORN** and **BELL** buttons on your transformer appear to be reversed (i.e., trigger the other sound), simply switch the wire connections at the transformer terminals.

Locomotive basics

Adding smoke fluid to your locomotive's smoke generator

Your locomotive is equipped with a smoke generator that produces safe, clean, white smoke during operation. Add 10-20 drops to the exhaust stack (shown in Figure 3) to prime the unit the first time you run the locomotive or after being stored for an extended period of time, and then add 10 to 20 drops to refill when smoke production decreases. When refilling, DO NOT EXCEED 20 DROPS as this can cause your smoke units to become oversaturated allowing leakage onto the electronics. Note that operating your locomotive's smoke unit without smoke fluid will cause damage to the heating element.

If you prefer to operate your locomotive without smoke, locate the smoke unit switch and slide it to the NO SMK position. Refer to Figure 4 on page 8 for the location of the switch.

Note! For best performance, we recommend using Lionel smoke fluid only.

Note! You may find it helpful to add smoke fluid using the funnel that is packed with this locomotive.

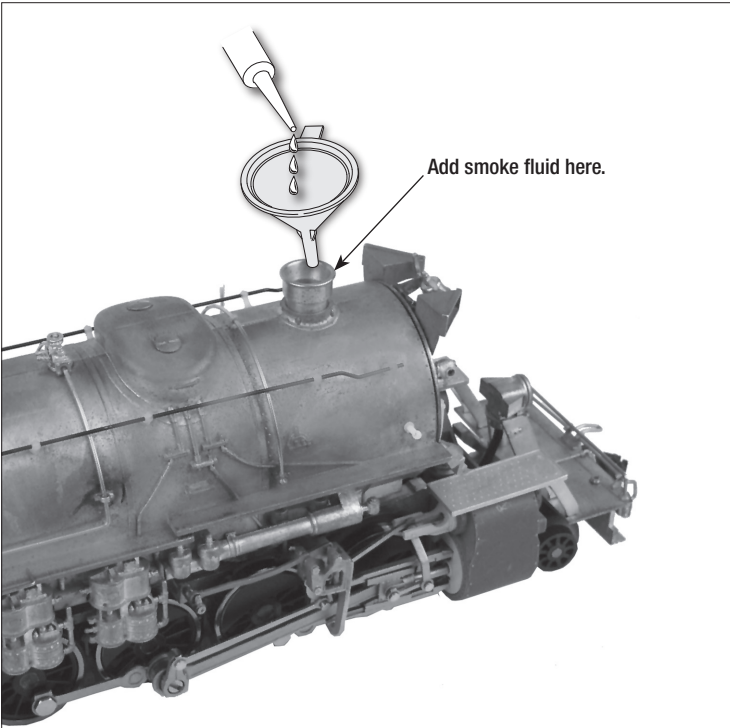

Figure 3. Smoke fluid location

Locomotive basics

Locomotive switch locations

The functions of your locomotive's switches are outlined below. Refer to Figure 4 for the location of the switches. **The instructions below are specific to this particular locomotive; note that available features (and switches) may differ from other locomotives and locomotive sets.**

Smoke Unit Switch (SMK/NO SMK)

Used to turn the smoke unit function on and off. Be sure that track power is off when you throw the switch

Program-Run Switch (RUN/PGM)

Used to assign an ID# and to reprogram the locomotive for LEGACY and Command operation when the switch is in the PGM position. Also used to “lock” your powered locomotive in a single direction, or neutral, in conventional operation when the switch is placed in the PGM position.

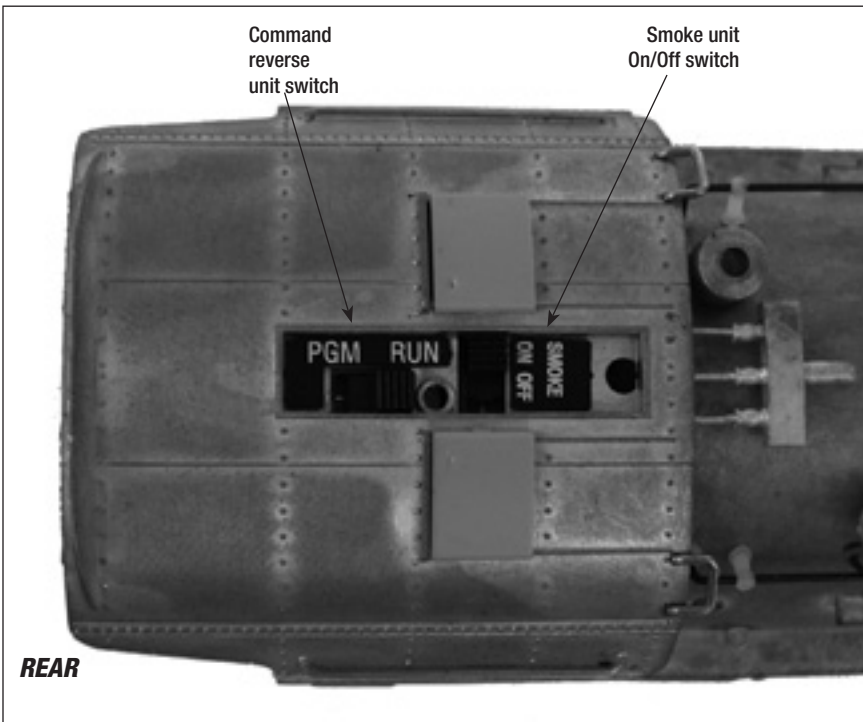

Figure 4. Locomotive switch locations

Locomotive basics

Assigning your locomotive a new ID# (LEGACY and TMCC)

For operation in the LEGACY or TMCC environment, you will want to give each unit a unique ID#. The locomotive will respond to commands associated with its ID# while all other units will disregard these commands. ***This procedure is not necessary for conventional (non-Command) operation.***

- 1. Slide the Command reverse unit switch on your locomotive to the PGM position. See Figure 4 on page 8.**
- 2. Place the locomotive on the track.**
- 3. Connect the Command Base and plug it in.**
- 4. Power up the track.**
- 5. Press ENG on the CAB-1 or CAB-2 remote.**
- 6. Enter the unique ID#. Choose any number from 1 to 98 that has not been assigned to another locomotive (ENG). We recommend using a part of your locomotive's road number.**

Note! All LEGACY locomotives respond to ENG 99. We recommend that you reserve ID# 99 as a "universal" ID#.

- 7. Press SET. The locomotive's horn will sound, or the headlights will flash if the RailSounds sound system is off.**
- 8. Slide the Command reverse unit switch back to the RUN position.**
The locomotive's ID# has been set. Be sure to record the new ID# for your reference.

Locomotive basics

Lash-ups (for LEGACY operations only)

In the Command environment, building a lash-up allows you to control your locomotive as one in a prototypical manner. It is still possible to control any of the engines in the lash-up individually. When you issue a train command, the individual engine you were controlling will return to the group.

To build a lash-up, assign a unique engine (ENG) ID# to each unit. See page 9 for details.

1. Address the train ID# you wish to create or edit, 1 to 99.
2. Press INFO.
3. Press BUILD softkey (button directly under BUILD).
4. Enter the front engine number. It is not necessary to enter ENG, just enter the #. It will appear in the blinking box.
5. Press ADD to add the front engine. The engine will move to the right and the blinking box will be ready for your next engine to be added.
6. Enter the second engine ID# in the blinking box.
7. Press ADD to add the second engine. The engine will move to the right and the blinking box will be ready for your next engine to be added.
8. Add all the engines you want in your lash-up in this manner.
9. To change the direction of an engine in your lash-up, turn the Velocity Throttle to move the engine you want into the blinking box. Then press DIR to change the direction of the engine.
10. To delete an engine in your lash-up, turn the red Velocity Throttle knob to move the engine you want to delete into the blinking box. Then press DEL.
11. To save your lash-up, press SET. Watch the onscreen prompts and wait until you see the message TRAIN CREATED.
12. Press CTC to exit to the operating screen.

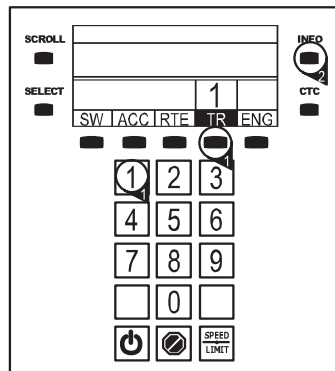

See reference numbers 1 and 2

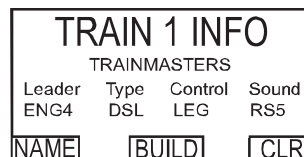

See reference number 3



See reference number 4

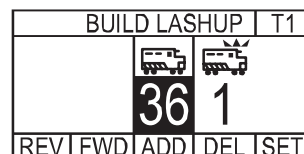

See reference numbers 6 and 7

LEGACY Control System operations

The LEGACY CAB-2 Remote Controller

Main Display

Displays real-time information about your railroad system. Displays real-time feedback of operation.

Scroll Button

Navigates through the entire list of Engines, Trains, Switches, etc

Select Button

Performs addressing by 3-4 digit road number.

Touch Screen Key Pad

A group of touch sensitive keys with icons for each function. These keys serve many purposes and their icons change accordingly.

Train Brake Slider

This slider is used to increase or decrease the amount of Train Brake affecting the engine or train.

Train Link Button

Quick select of Train-Link devices (LEGACY Control System Version 1.3)

AUX-1/Thru Button

Press to view the Control Panel while operating. Controls switch direction.

Emergency Halt Button

Stops everything on layout; also stops recording playback.

AUX-2/Out Button

Controls switch direction. Toggles all directional lights on/off.

Record Button

Used to record and play back events.

Velocity Throttle

Throttle control over engines, also used to navigate thru info/options.

Set Button

Used to set Engine address and for programming.

Used to enter/view the info/options of selected components.

Info Button

CTC Button

Press and hold to turn your remote on and off. Tap this button to enter the remote and base options. Tap it again to return to the main screen.

Soft Keys

These keys directly correlate to the 5 selection boxes located at the bottom of the main display. These are also used in the info/options menus to select options.

Warning Sound Controller

Warning Bell and Variable Horn control. Pull down to sound Horn. Push up and release to trigger Warning Bell.

Multi Controller

Boost, Brake, and Direction control. Rock forward for Boost, rock backward for engine brake, and press down for direction change. Click-hold-and rock for absolute direction selection.

Front & Rear Coupler Buttons

Fire couplers.

Feedback Button

Toggle ON/OFF the vibration feedback feature in the CAB-2 Remote.

Official R.R. Speed Control Bar

Toggles the touchscreen display of R.R. preset speeds and control panel.

Low, Medium, High Momentum Buttons

Used to select the desired momentum of your addressed engine/train/accessory.

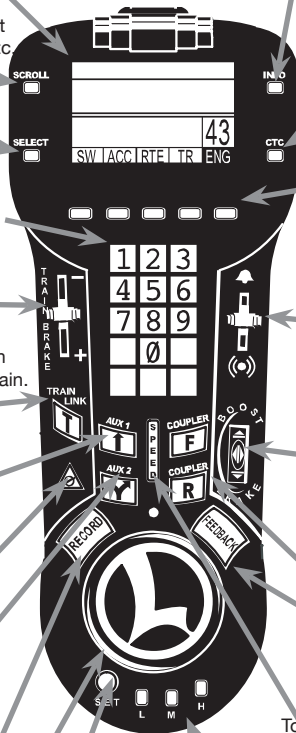

LEGACY Control System operations

Note! This section is a brief overview of the LEGACY Control System. For a more in-depth explanation of the LEGACY Control System features, please see your LEGACY Control System Operations Manual, available online at www.lionel.com.

The Velocity Throttle

The Velocity Throttle (the red rotary knob on the bottom of your Lionel remote) is used to start your engine moving, slow it down, or speed it up. Use it simply by turning it clockwise (speed up) or counter-clockwise (slow down).



The Multi-Controller

Direction

The direction of your engine toggles between forward and reverse at the touch of the Multi-Controller. Press the center of the Multi-Controller once, and your engine's lights will change directions and the engine will stop until you throttle up again in the new direction.

Boost & Brake

Boost and brake give you another way to control the speed of your train. Boost gives your loco a temporary increase in tractive power, and returns to the previous speed when you release the control, while the brake command slows you down more quickly than the Velocity Throttle alone.

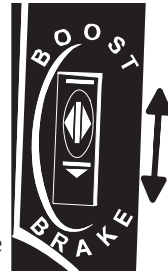

The Train Brake Slider

The Train Brake is used to slow down and limit the top speed of your train by adding a load. The more the Train Brake is applied by pulling the Train Brake Slider down, the more laboring is heard from the engine. Eventually Train Brake application will slow down the train and it is even possible to stop a train by pulling the Train Brake Slider all the way down.

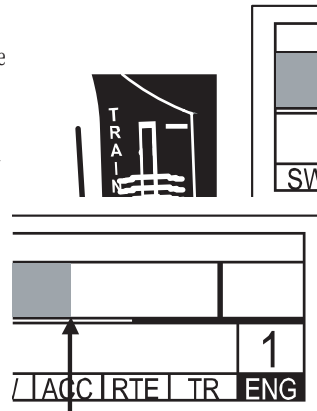

LEGACY Control System operations

The Warning Sound Controller

Warning sounds are an important part of Lionel Railroading. Your Lionel Legacy Control System equipped engines have a real-time variable "quilling" horn.

Blow the Horn by pulling down on the Warning Sound Controller. Notice the difference in intensity of the horn sound.

Strike the bell once by pushing the Warning Sound Controller up and releasing quickly. To activate continuous bell sounds, push the Warning Sound Controller up and hold it for 1.5 seconds. To discontinue the bell sounds, push and hold the Warning Sound Controller up until the bell stops.

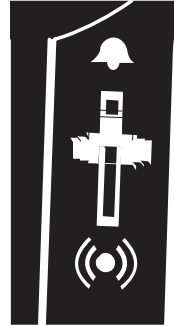

The Speed Bar

The Speed Bar is used to select a new touch-screen Icon Control set. This set of touch-screen keys is used to select prototypical preset speeds. The speed of the engine changes with each press and release of a different Preset Speed key.

- Tap a key, and your locomotive will immediately begin moving to that speed.
- Press and hold a key, and you'll hear the dispatcher radio the engineer and order him to move to that speed.
- If you hold the key until the dialog is finished, the engineer will indicate that he is "increasing to...", "slowing to...", or "we are at..." the command speed.

You can also use the Velocity Throttle and other action controls in this mode and continue to use Preset speeds at the same time.

Press **AUX1** to leave the Preset speed mode and return to the Standard Control Panel. Press the speed bar to toggle between the Speed Control Panel and the Standard Control Panel.

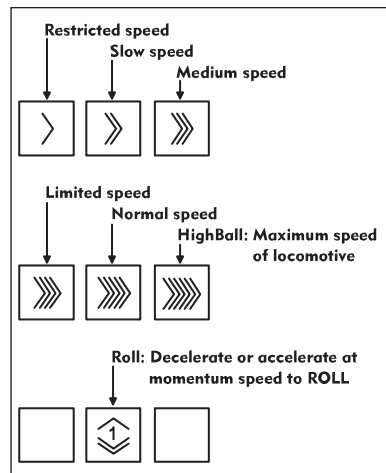

Note! Switcher engines do not have preset speed dialog.

Note! Depending on the track resistance (e.g., at curves or inclines), your locomotive may not start to move at Roll or Restricted speeds.

LEGACY Control System operations

EFX Trim and EFX Bar Graph

The sound of the engine can be trimmed slightly higher or lower depending on your operating preference. Pressing the EFX up button will make the engine sound like it is working harder. Similarly, the EFX down button will decrease the laboring sound of the engine. A RESET command will return the EFX trim to its default setting.

Notice that the current EFX level is displayed on the remote as a bar graph inside the soft key to the left of the ROLL button on the keypad display. The height of this graph varies with the EFX keys, throttle and train brake adjustments.

Leaving the Preset Speed Screen

Use the Speed Bar to leave the Speed Panel and return to the Control panel. Press the Speed Bar to toggle between the Speed Control Panel and the Standard Control Panel.

LEGACY RailSounds sound system operations

LEGACY RailSounds sound system

Volume UP

Raises the overall master volume of the LEGACY RailSounds sound system. To independently adjust the level of the background sounds only (e.g., the diesel roar and brake sounds), tap AUX1 and then this key.

CrewTalk

Engineer begins radio dialog, dispatcher replies.

RPM Levels

Adjusts the level of the RPM sounds.

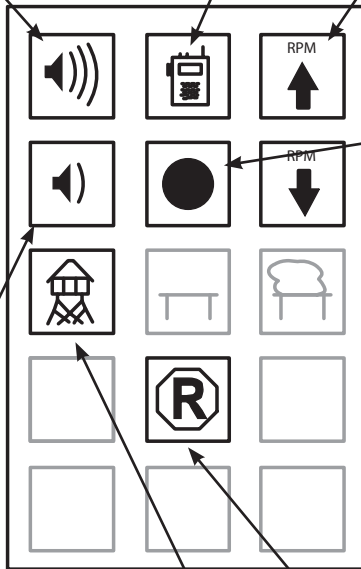

RailSounds Shutdown

Activates the LEGACY RailSounds sound system shutdown sequence when stopped. **OR**

Emergency Stop

Activates the emergency stop feature while in motion. Icon will change (see below) as the state of the locomotive changes.



Volume DOWN

Lowers the overall master volume of the LEGACY RailSounds sound system. To independently adjust the level of the background sounds only (e.g., diesel roar and brakes), tap AUX1 and then this key. Volume settings are retaining when track power is turned off.

Stops and resets the locomotive

Resets the locomotive's direction to forward. Press and hold to activate a fueling sequence. Fueling sounds.

TowerCom

Dispatcher begins radio dialog, engineer replies. See page 16.

LEGACY RailSounds sound system operations

Installing the battery

Although the LEGACY RailSounds sound system is powered through the track, we recommend that you install a nine-volt alkaline battery in the tender to prevent the sound system from shutting down during track power interruptions (for example, over a dirty section of track). Follow these steps and refer to Figure 5 as you install the battery.

Note! If the RailSounds sound system turns off during interruptions in track power, you may need to replace the battery.

1. Remove the six body screws from the underside of the tender. Refer to Figure 5 below for the location of the screws.
2. Carefully lift the body off the frame. Be careful to avoid pulling on the wires that connect the body to the frame.
3. Remove the protective cover from the battery harness.
4. Snap the battery harness onto the nine-volt alkaline battery's terminals.
5. Slide the battery into the battery holder, which is attached to the frame.
6. Replace the body and secure it with the body mounting screws. Be careful to avoid pinching wires between the body and frame.

Note! To prevent damage to the body, do not overtighten the screws.

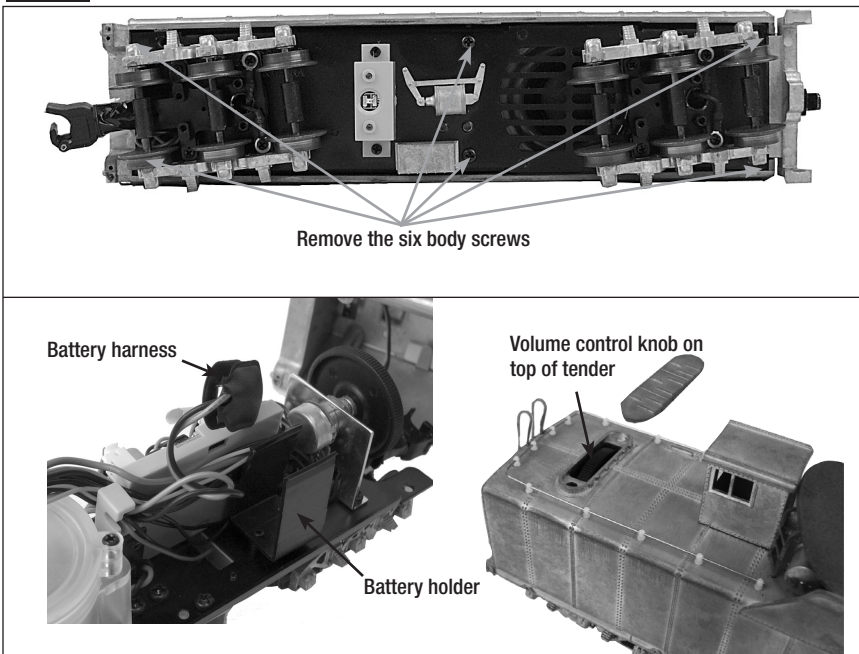

Figure 5. Battery and volume control knob

LEGACY RailSounds sound system operations

CrewTalk dialog and TowerCom announcements in the LEGACY environment

CrewTalk dialog and TowerCom announcements feature a variety of brief radio conversations between the engineer and dispatcher. CrewTalk dialog is an engineer-initiated radio conversation with the dispatcher. TowerCom announcements are a dispatcher-initiated radio conversation with the engineer. Be sure to listen for the different combinations of words and phrases that comprise these exchanges.

Refer to Table 1 below for the dialog commands. The dialog in the table provides examples of the conversations you can trigger. The actual dialog will vary.

Locomotive	Commands	Example dialog
Stopped	AUX1, 2	Crew: Ask To Depart Tower: Deny Departure
	AUX1, 7	Tower: Ask To Standby Crew: Acknowledge
	2	Crew: Ask To Depart Tower: Approve Departure
	7	Tower: Approve Departure Crew: Acknowledge
	5 or AUX1, 5	Crew: Shutdown Announcement Shutdown sequence
	AUX1, 0	Refueling sequence Crew: My tank is full
Moving	2	(recent departure) Crew: Train is underway Tower: Acknowledge
	2	Crew: Are we clear ahead? Tower: Acknowledge
	AUX1, 2	Crew: Report engine status
	7 or AUX1, 7*	Tower: Clear in-bound Crew: Acknowledge
	5 or AUX1, 5	Tower: Emergency stop Crew: Acknowledge

Table 1. LEGACY Remote Controller dialog commands

*Activating **7** or **AUX1, 7** while the locomotive is in motion enables an arrival conversation for 30 seconds. If the train stops within this time, pressing **2** will play this special conversation.

LEGACY RailSounds sound system operations

LEGACY RailSounds sound system dialog on a round trip

Refer to Figure 5 for a sample dialog script for manually controlled dialog on the locomotive's round trip using the numeric keypad.

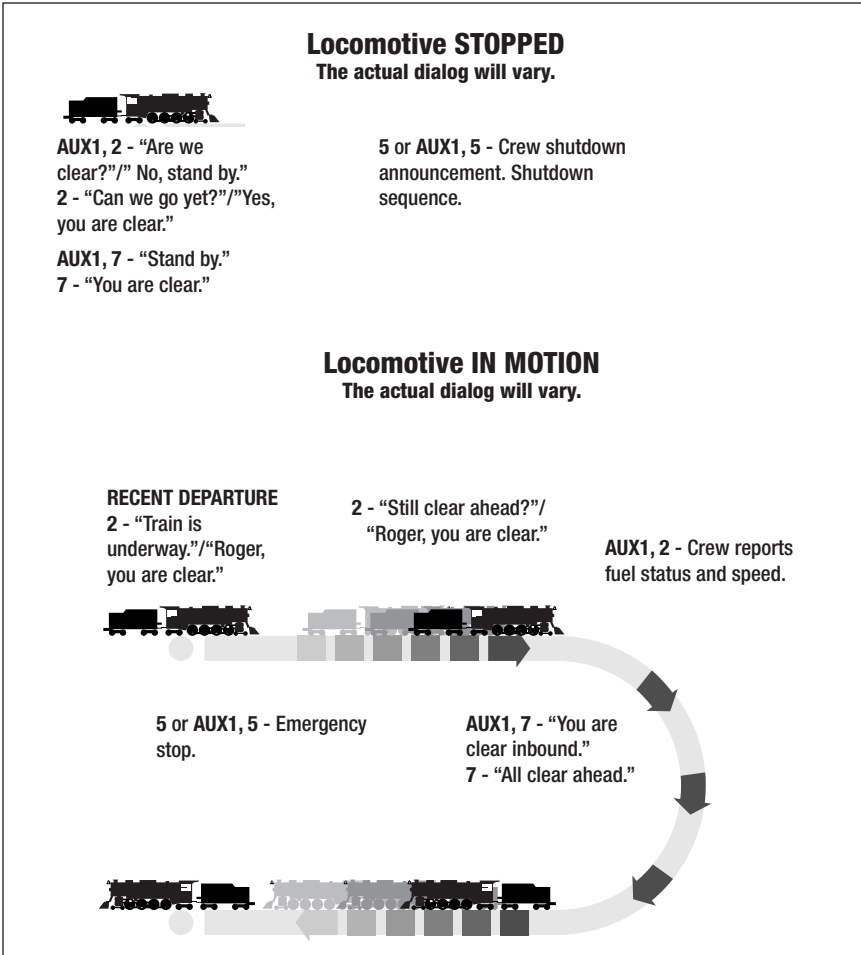

Figure 6. LEGACY RailSounds sound system dialog on a round trip

TrainMaster Command Control operations

CAB-1 Remote Controller commands

The CAB-1 Remote Controller commands are detailed below. The corresponding RailSounds sound system effects are in bold italic type.

 Releases the ElectroCoupler on the front of the locomotive. *Coupler release sound.*

 Releases the ElectroCoupler on the rear of the tender. *Coupler release sound.*

 Activates the numeric keypad. *Short air release sound.*

 Controls switch direction. Toggles all directional lights on/off.

 Accelerates the locomotive with a clockwise rotation. Decelerates the locomotive with a counter-clockwise rotation. *Speed-dependent RPM sounds.*

 Activates the locomotive's horn. Release the button to discontinue the sound. *Horn sound.*

 Toggles the bell sound on and off. *Bell sound.*

 Changes the locomotive's direction. The locomotive decelerates to a stop and continues in the opposite direction when you increase the throttle. *Air release sound.*

 Increases the locomotive's speed while the button is pressed. Release the button to return to the initial speed. *Labored prime mover.*

 Decreases the locomotive's speed while the button is pressed. *Squealing brake sounds.*

 Shuts down all PowerMasters on your railroad. Stops all TrainMaster Command Control-equipped locomotives in operation. Use **HALT** only in emergency situations.



- L** 32 speed steps with low momentum
- M** 100 speed steps with low momentum
- H** 100 speed steps with medium momentum

TrainMaster Command Control operations

CAB-1 Remote Controller numeric keypad commands

When you press the AUX1 button on your CAB-1 Remote Controller, you turn the numeric keypad into ten command buttons. After you press the **AUX1** button, you will be able to press any numbered button until you address a different product. *The corresponding RailSounds sound system effects are in italic type.*



Stops and resets the locomotive. Resets the locomotive's direction to forward.



Raises the volume of the background sounds by tapping **AUX1** and then this key. Volume settings are retained when track power is turned off. *Sound volume increases.*



Engineer begins radio dialog, dispatcher replies (see page 18). *CrewTalk communication.*



Enters manual RPM mode and increases the RailSounds sound system RPM level. If the LEGACY RailSounds sound system is shut down (see **5** key below), **AUX1, 3** activates a full LEGACY RailSounds sound system start-up while the locomotive is stopped after pressing **AUX1, 5** with track power on.



Lowers the volume of the background sounds by tapping **AUX1** and then this key. Volume settings are retained when track power is turned off. *Sound volume decreases.*



Activates the LEGACY RailSounds sound system shutdown sequence when stopped. Activates the emergency stop feature while in motion. Note that, in the shutdown sequence, the smoke unit will turn off if it was already on.

TrainMaster Command Control operations

CAB-1 Remote Controller numeric keypad commands (continued)



Enters manual RPM mode and lowers the LEGACY RailSounds diesel motor RPM level.



Dispatcher begins radio dialog, engineer replies (see page 16). *TowerCom announcement.*



Turns off the smoke units. *Air release sound.*



Turns on the smoke unit if the smoke unit switch is in the ON position. Be sure to add smoke fluid before turning on the smoke unit to prevent damage to your locomotive. *Air release sound.*

Note! **AUX1**, **8** and **9** function only if the locomotive's smoke unit switch is in the ON position.

Controlling the smoke level and cab lights

You may adjust the level of smoke production using your Remote. Use the sequences below.

Low smoke production:	AUX1, AUX2, 9, L, AUX2
Medium smoke production:	AUX1, AUX2, 9, M, AUX2
High smoke production:	AUX1, AUX2, 9, H, AUX2

You may turn the cab lights on or off using your remote. Use the sequence below.

Toggle cab lights ON/OFF	AUX2, BRAKE, AUX2
--------------------------	--------------------------

Conventional transformer operations

Using the LEGACY RailSounds sound system in the conventional environment

When you first power up your locomotive, you will hear the sounds of the locomotive at rest. As the locomotive moves, the RPM sounds automatically increase with the locomotive's speed. In the conventional environment, the horn and bell sounds are activated by your transformer controls, if so equipped.

To adjust the volume, use the volume control knob. Refer to Figure 4 on page 8 for the location of the volume control knob.

In the conventional environment, you will experience several features of the LEGACY RailSounds sound system.

- **Diesel motor RPM levels.** The level of diesel motor RPM level automatically varies with the speed of the locomotive.
- **MultiHorn.** A different horn sound at different speeds.
- **Mechanical bell.** Press BELL on your transformer to begin the effect, then press BELL a second time to discontinue the effect.
- **CrewTalk dialog and TowerCom announcements.** These brief conversations between the train crew and the tower are triggered by short horn blasts.

Note! If the **HORN** and **BELL** buttons on your transformer appear to be reversed (i.e., trigger the other sound), simply switch the wire connections at the transformer terminals.

Activating the CrewTalk dialog and TowerCom announcements

In the conventional environment, CrewTalk dialog and TowerCom announcements are triggered by short horn blasts and vary with the state of the locomotive.

- If the locomotive has been stopped for less than 15 seconds, a short horn blast triggers a "please standby" dialog.
- If the locomotive has been stopped for longer than 15 seconds, a short horn blast triggers a "cleared outbound" dialog.
- If the locomotive has started moving within the last seven seconds, a short horn blast will trigger a "train is underway" dialog.
- If the locomotive has been moving for more than seven seconds, a short horn blast will trigger a "are we clear?" dialog.
- If the locomotive has been moving and the bell is ringing, a short horn blast will trigger a "go to restricted speed" dialog.

Conventional transformer operations

Locking your locomotive into a single direction

When the Command reverse unit switch is in the RUN position on the powered unit, your locomotive sequences through a repeating pattern of operations: forward, neutral, reverse, neutral, and so on.

To “lock” your locomotive into a single direction (for example, to operate in forward only), you can deactivate the Command reverse unit’s sequencing function.

- 1. Use your transformer’s DIRECTION button or interruptions in track power to get your locomotive moving slowly in the desired direction or into neutral.**
- 2. Slide the Command reverse unit switch on the powered unit to the PGM position. At this point, the locomotive is “locked” into your chosen direction. See Figure 4 on page 8 for the location of this switch.**

To restore the forward-neutral-reverse sequence, just slide the Command reverse unit switch back to the RUN position.

Maintaining and servicing your locomotive

Reprogramming your locomotive to restore features (LEGACY)

If your locomotive is unresponsive to your commands in the Command Control environment, we recommend that you follow this procedure to reset your locomotive. All factory default settings will be restored when you reprogram the locomotive.

- 1. Slide the program run switch to the PGM position.**
- 2. Plug in and connect your LEGACY Base.**
- 3. Place your locomotive on the track, then power up the track.**
- 4. Press ENG and enter the locomotive's ID#.**
- 5. Press SET.**
- 6. Slide the program run switch back to the RUN position.**

At this point, your locomotive has been reset. Restore power to the track and operate the locomotive as usual. Be sure to use the ID# entered in Step 4.

Reprogramming your locomotive to restore features (TMCC)

If your locomotive is unresponsive to your commands in the Command Control environment, we recommend that you follow this procedure to reset your locomotive. All factory default settings will be restored when you reprogram the locomotive.

- 1. Slide the program run switch to the PGM position.**
- 2. Plug in and connect your Command Base.**
- 3. Place your locomotive on the track, then power up the track.**
- 4. Press ENG and enter the locomotive's ID#.**
- 5. Press SET.**
- 6. Slide the program run switch back to the RUN position.**

At this point, your locomotive has been reset. Restore power to the track and operate the locomotive as usual. Be sure to use the ID# entered in Step 4.

Maintaining and servicing your locomotive

Lubricating your locomotive

Help your Lionel locomotive lead a long and productive life on your railroad by maintaining it properly. To keep your locomotive lubricated, we recommend that you purchase a Lionel Lubrication and Maintenance Kit (6-62927), available from your authorized Lionel dealer.

When you find that the lubrication points illustrated in Figure 7 appear dry, lubricate your locomotive after you have removed any accumulated dirt and dust. There are two basic rules to keep in mind when you are lubricating your locomotive: use only a small amount of lubrication and avoid getting grease or oil on your locomotive's wheels, roller pick-ups, or the track.

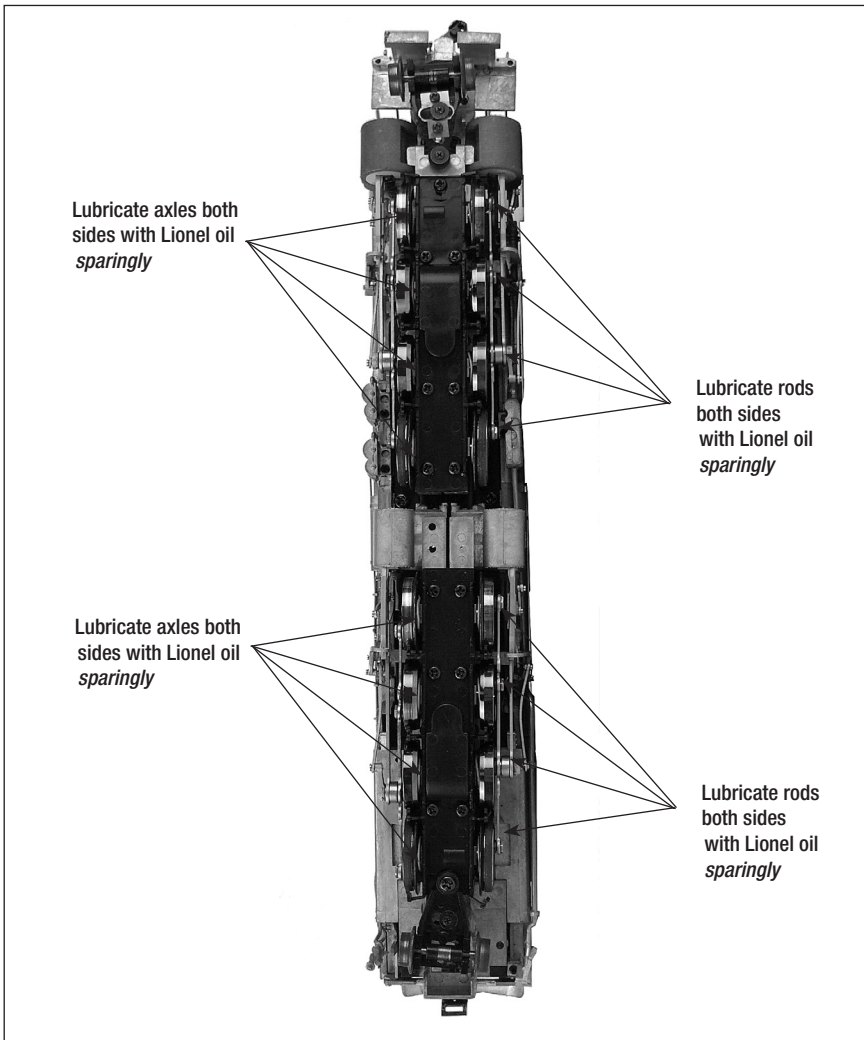

Figure 7. Lubrication points

Maintaining and servicing your locomotive

Servicing your locomotive's LEDs

Note! If the locomotive is powered up and the lights are not on, check that the **AUX2** command was not used to turn the lamps off.

Your locomotive is illuminated by several LEDs that are expected to last for the life of the locomotive. The LED's are not user serviceable. If service is required, we recommend that you have your locomotive serviced at a Lionel Factory Trained Authorized Service Station.

Replacing the traction tires

Your locomotive is equipped with traction tires to increase the tractive effort of your locomotive and allow it to pull more cars at one time.

During the course of normal operations, the traction tires may become worn out. Replacement traction tires are included with the locomotive. We recommend that you have the traction tires replaced by an authorized Lionel dealer or service station because the drive linkage must be removed to access the wheels. See **Instructions for Obtaining Service** on page 28 for more information.

Notes

Lionel Limited Warranty Policy & Service

This Lionel product, including all mechanical and electrical components, moving parts, motors and structural components, with the exception of **LIGHT BULBS, LED's & TRACTION TIRES** are warranted to the original owner-purchaser for a period of **one year from the original date of purchase** against original defects in materials or workmanship when purchased through a **Lionel Authorized Retailer***.

This warranty does **NOT** cover the following:

- Normal wear and tear
- Light bulbs or LED's
- Defects appearing in the course of commercial use
- Damage resulting from abuse/misuse of the product

Transfer of this product by the original owner-purchaser to another person voids this warranty in its entirety. Modification of this product in any way; visually mechanically or electronically, voids the warranty in its entirety.

Any warranted product which is defective in original materials or workmanship and is delivered by the **original owner-purchaser** (this warranty is non-transferrable) to Lionel LLC or any Lionel Authorized Service Station **MUST** be accompanied by the original receipt for purchase (or copy) from an **Authorized Lionel Retailer***, will at the discretion of Lionel LLC, be repaired or replaced, without charge for parts or labor. In the event the defective product cannot be repaired, and a suitable replacement is not available, Lionel will offer to replace the product with a comparable model (**determined by Lionel LLC**), if available. In the event a comparable model is not available the customer will be refunded the original purchase price (requires proof of purchase from the **Authorized Lionel Retailer*** it was originally purchased). Any products on which warranty service is sought must be sent freight or postage prepaid (Lionel will refuse any package when postage is due). **Transportation and shipping charges are not covered as part of this warranty.**

NOTE: Products that require service that do not have a receipt from an LIONEL AUTHORIZED RETAILER* will be required to pay for all parts required to repair the product (labor will not incur a charge) providing the product is not older than 3 years from date of manufacture and is within 1 year from date of purchase. A copy of the original sales receipt is required.

In no event shall Lionel LLC be held liable for incidental or consequential damages.

Some states do not allow the exclusion or limitation of incidental or consequential damages, so the above exclusion may not apply to you.

This warranty gives you specific legal rights and you may have other rights which vary from state to state.

Instructions for Obtaining Service

If service for this Lionel LLC product is required, bring the item, along with your DATED sales receipt and completed warranty information (at the bottom of this page) to the nearest Lionel Authorized Service Station. Your nearest Lionel Service Station can be found by calling 1-800-4-LIONEL or by accessing the website at www.lionel.com.

If you prefer to send your Lionel product directly to Lionel, for repair you must FIRST call 586-949-4100 extension 9105 or FAX Lionel at 586-949-5429 or write to Customer Service, 26750 Twenty Three Mile Road, Chesterfield, MI 48051-2493. Please have the 6-digit Lionel product number, the date of original purchase, the dealer where the item was purchased and what seems to be the problem. You will receive a return authorization (RA) number to ensure your merchandise will be properly tracked and handled upon receipt at Lionel LLC.

Once you have your Return Authorization (RA) number, make sure the item is packed in its original Styrofoam inner container which is placed inside the original outer display box (this will help prevent damage during shipping and handling). This shipment **MUST** be prepaid and we recommend that it be insured with the carrier of your choice.

Please make sure you have followed all of the above instructions carefully before returning any merchandise for service. You may choose to have your product repaired by one of Lionel LLC's Authorized Service Stations after its warranty has expired. A reasonable service fee should be expected once the product warranty has expired.

Warranty Information

Please complete the information below and keep it, along with your **DATED ORIGINAL SALES RECEIPT**. You **MUST** present this form **AND** your **DATED SALES RECEIPT** when requesting warranty service.

*A complete listing of Lionel Authorized retailers can be found by calling 1-800-4-LIONEL or by visiting our website at www.lionel.com.

Products that are more than 3 years old, from date of manufacture, are not applicable for warranty coverage, even if they have never been sold prior to this date. (Under no circumstance shall any components or labor be provided free of charge.)

Name _____

Address _____

Place of Purchase _____

Date of Purchase _____

Product Number _____

Product Description _____



© 2012 LIONEL L.L.C., CHESTERFIELD, MI 48051
UNITED STATES OF AMERICA
PRINTED IN CHINA